

TB2

Reference Torque Measuring Discs



Standard version



Option: Degree of protection IP67

Special features

- Accuracy class 0.03
- Nominal torques from 500 N·m to 10 kN·m
- High vibration bandwidth
- Classification acc. to DIN 51309 and EA 10–14 class 0.05 possible in conjunction with calibration certificate
- Option: Degree of protection IP67 according to EN 60529

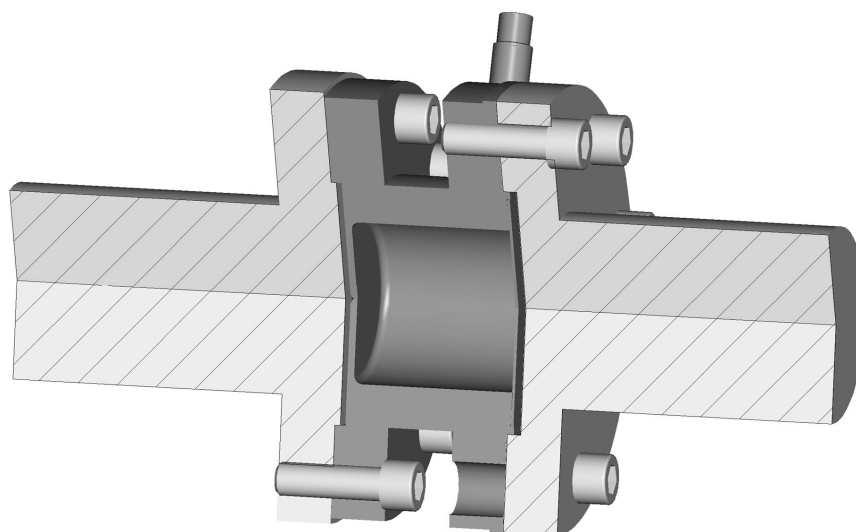

Specifications

Type		TB2						
Accuracy class		0.03						
Nominal torque M_{nom}	N-m	500						
	kN-m		1	2	3	5	10	
Nominal sensitivity (nominal signal span between torque = zero and nominal torque)		mV/V	1					
Sensitivity tolerance (deviation of the actual output quantity at M_{nom} from the nominal signal span)		%	< ± 0.1					
Temperature effect per 10 K in the nominal temperature range								
On output signal (related to actual value)		%	< ± 0.03					
On zero signal (related to nominal sensitivity)		%	< ± 0.02					
Linearity deviation, including hysteresis, (related to nominal sensitivity)		%	< ± 0.03					
Relative standard deviation of repeatability according to DIN 1319 (related to variation of output signal)		%	< ± 0.01					
Input resistance at reference temperature		Ω	1550 ± 100					
Output resistance at reference temperature		Ω	1000 – 1400					
Reference excitation voltage		V	5					
Operating range of the excitation voltage		V	2.5 ... 12					
Emission (according to EN61326–1, table 4) RFI field strength			Class B					
Immunity from interference (EN 61326-1, table A.1)								
Electromagnetic field AM		V/m	10					
Magnetic field		A/m	100					
ESD								
Contact discharge		kV	4					
Air discharge		kV	8					
Burst		kV	2					
Surge		kV	1					
Line-conducted disturbance (AM)		V	10					
Degree of protection according to EN 60 529		–	IP54, option IP67					
Nominal temperature range		°C	+10...+60					
Operating temperature range		°C	–10...+80					
Storage temperature range		°C	–20...+80					
Impact resistance, test severity level to IEC 68; part 2-27; IEC 68-2-27-1987								
Number of impacts		n	1000					
Duration		ms	3					
Acceleration (half-sine)		m/s ²	650					
Vibration resistance, test severity level to IEC 68; part 2-6; IEC 68-2-6-1987								
Frequency range		Hz	5 ... 65					
Duration		h	1.5					
Acceleration (amplitude)		m/s ²	50					
Load limits ¹⁾								
Limit torque, related to M_{nom}		%	200		160			
Breaking torque, related to M_{nom}		%	>400		>320			
Axial limit force		kN	16	19	39	42	80	120
Lateral limit force		kN	4	5	9	10	12	18
Bending limit moment		N-m	200	220	560	600	800	1200
Vibration bandwidth according to DIN 50100 (peak-to-peak)		N-m	1000	2000	4000	4800	8000	16000

¹⁾ Each type of irregular stress can only be permitted with its given limit value (bending moment, lateral force or axial force, exceeding the nominal torque) if none of the others can occur. Otherwise the limit values must be reduced. If for instance 30 % of the bending limit moment and also 30 % of the lateral limit force are present, only 40 % of the axial limit force are permitted, provided that the nominal torque is not exceeded. With maximum additional loading, measuring errors of the order of approx. 0.2 % of the nominal torque can occur.

Specifications

Mechanical data							
Nominal torque M_{nom}	N·m	500					
	kN·m		1	2	3	5	10
Torsional stiffness	kN·m/ rad	540	900	2300	2600	4600	7900
Rotation angle at M_{nom}	°	0.055	0.066	0.049	0.066	0.06	0.07
Axial stiffness, approx.	kN/mm	900	970	1000	1100	950	1600
Radial stiffness, approx.	kN/mm	700	840	1400	1600	1400	2500
Stiffness with bending moment about a radial axis	N·m/ Grad	9500	9800	21700	22400	31400	71000
Max. deflexion at axial limit force	mm	< 0.03		< 0.05		< 0.1	
Additional max. concentricity error at lateral limit force	mm	< 0.01					
Additional plumb parallel deviation at bending limit moment	mm	< 0.04		< 0.06		< 0.1	
Mass moment of inertia (flange bolt not taken into account) of the rotor I_v (about longitudinal axis)	kg·m ²	0.0059		0.0192		0.037	0.097
Pro rata mass moment of inertia (measurement side)	%	57		55		54	
Weight, approx. (without cable)	kg	2.4		4.9		8.3	14.6
Weight, . IP67-Version, approx (with cable)	kg	2.6		5.1		8.5	14.8

Complementary data according to DIN 51309 or EA 10-14		
Class according to DIN 51309 or EA 10-14		0.05
Rel. error of the zero signal f_0 (zero point return), related to the full scale	%	< ± 0.008 (typically < 0.003)
Rel. repeatability and reproducibility errors (0.1 M_N to M_N), rel. to actual value		
in unchanged mounting position	%	< 0.02 (typically < 0.01)
in different mounting positions	%	< 0.03 (typically < 0.02)
Rel. reversibility error (0.1 M_N to M_N) h , related to the actual value	%	< 0.06 (typically < 0.03)

Scope of delivery:

TB2

Transducer connection cable, 3 m (Lemo FGG6 pigtails)

Test report

Mounting instructions

Option:

Degree of protection IP67 acc. to EN 60529

Order no.: D-TB2/IP67

Accessories:

Plug connector MS 3106PEMV, mounted to cable

Order no.: D-MS/MONT

15-pin D-Connector, mounted to cable

Order no.: D-15D/MONT

DKD calibration certificate according DIN 51309 or EA 10-4

Standard version

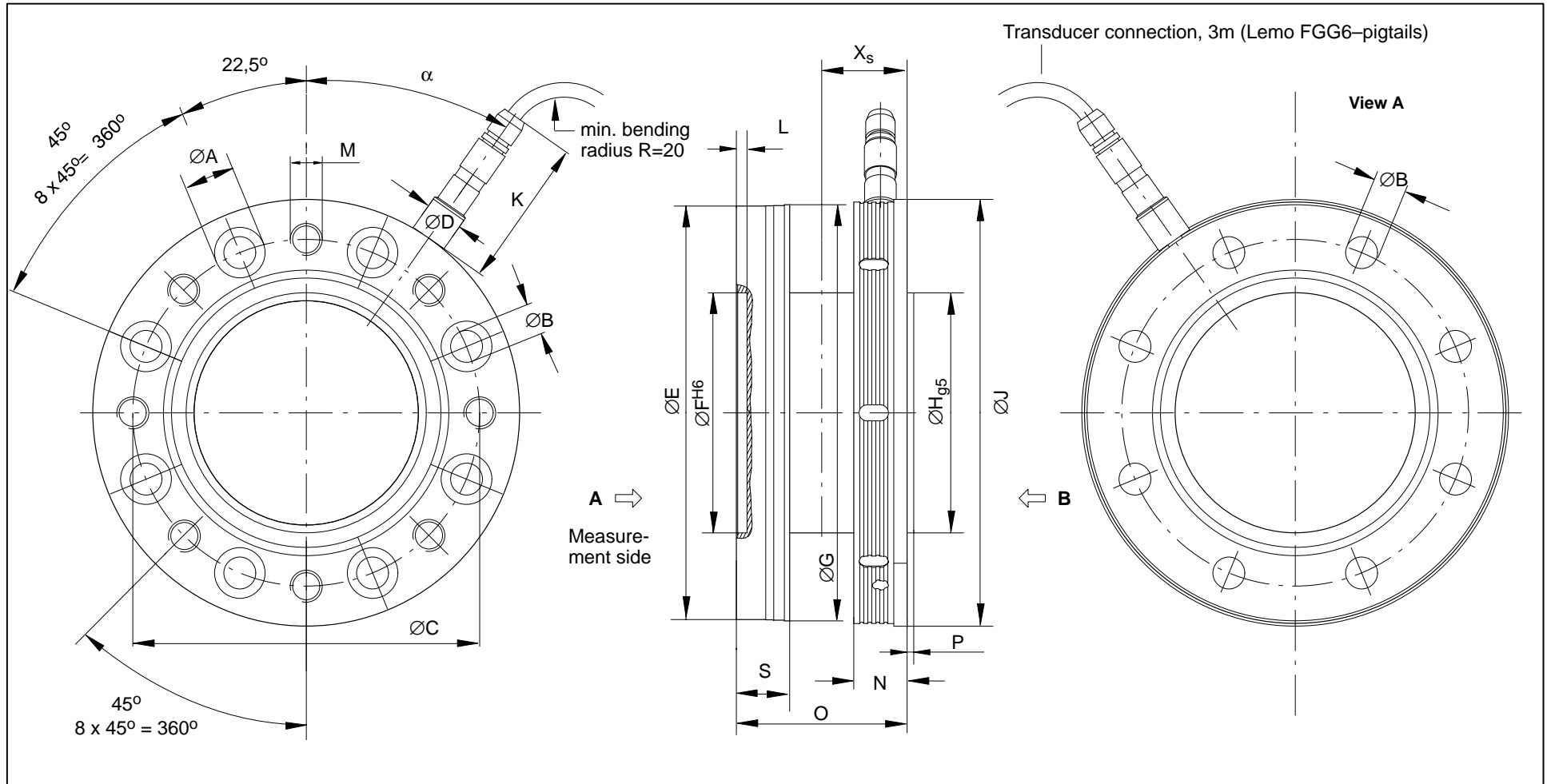

Nominal torque	$\varnothing A$	$\varnothing B$	$\varnothing C$	$\varnothing D$	$\varnothing E$	$\varnothing FH6$	$\varnothing G$	$\varnothing H_{g5}$	$\varnothing J$	K	α	M	S	L	N	O	P	X_s
500 N·m – 1 kNm	17	10	101.5	14	120	75	121	75	123	57	35.8	M10	18	4	18	60	$2^{+0.4}$	30
2 kN·m – 3 kN·m	19	12	130	14	155	90	156	90	160	57	35	M12	20	4	20	64	$2.5^{+0.4}$	32
5 kN·m	22	14.2	155.5	14	179	110	180	110	188	57	10	M14	26	3	26	84	2.8	42
10 kN·m	26	17	196	14	221	140	222	140	230	57	10	M16	30	4	30	92	$3.5^{+0.5}$	46

Option: Degree of protection IP67

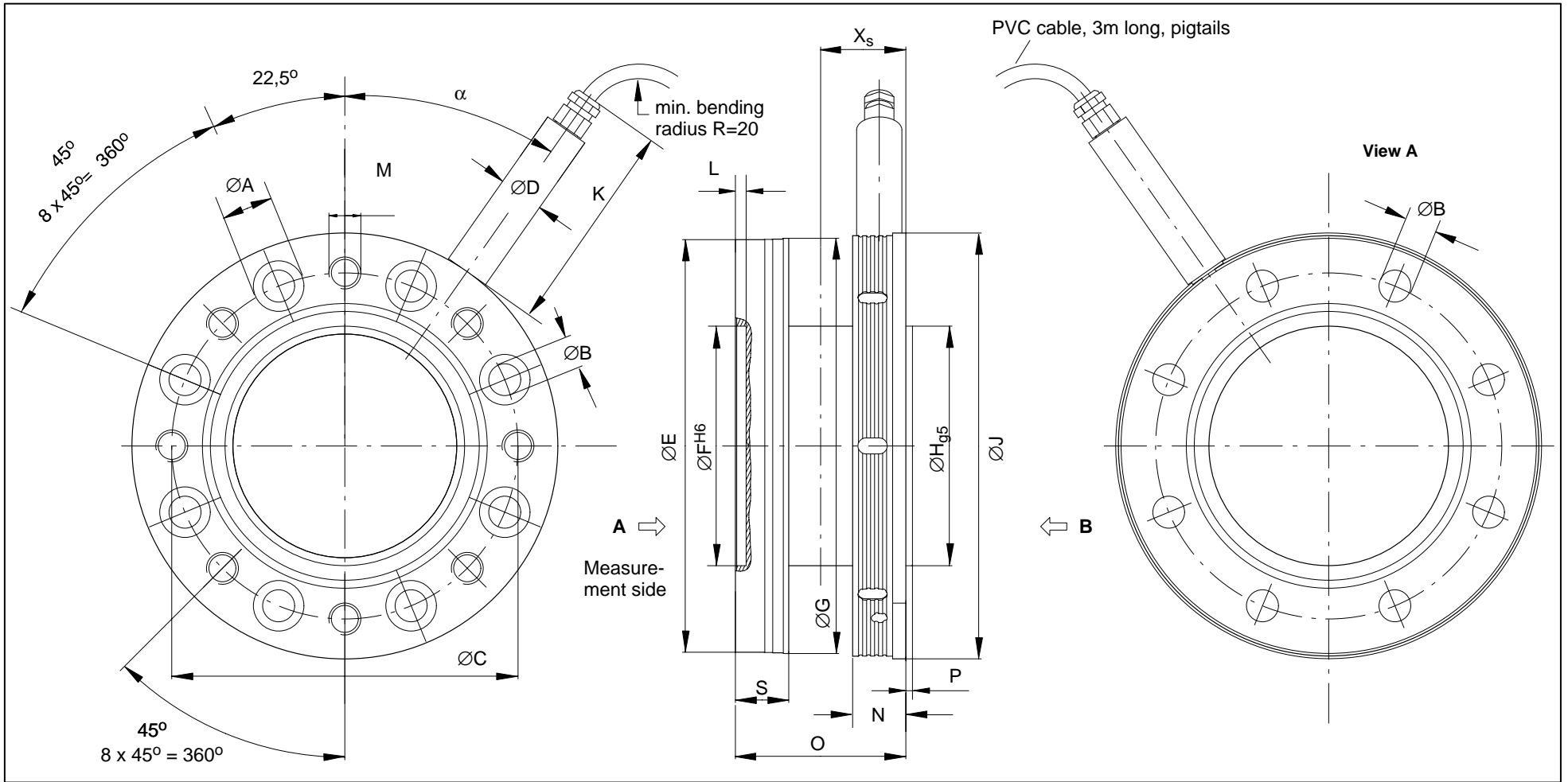

Nominal torque	$\varnothing A$	$\varnothing B$	$\varnothing C$	$\varnothing D$	$\varnothing E$	$\varnothing F_{H6}$	$\varnothing G$	$\varnothing H_{g5}$	$\varnothing J$	K	α	M	S	L	N	O	P	X_s
500 N·m – 1 kN·m	17	10	101.5	17	120	75	121	75	123	80	35.8	M10	18	4	18	60	$2^{+0.4}$	30
2 kN·m – 3 kN·m	19	12	130	17	155	90	156	90	160	80	35	M12	20	4	20	64	$2.5^{+0.4}$	32
5 kN·m	22	14.2	155.5	17	179	110	180	110	188	80	10	M14	26	3	26	84	2.8	42
10 kN·m	26	17	196	17	221	140	222	140	230	80	10	M16	30	4	30	92	$3.5^{+0.5}$	46

Runout and concentricity tolerances

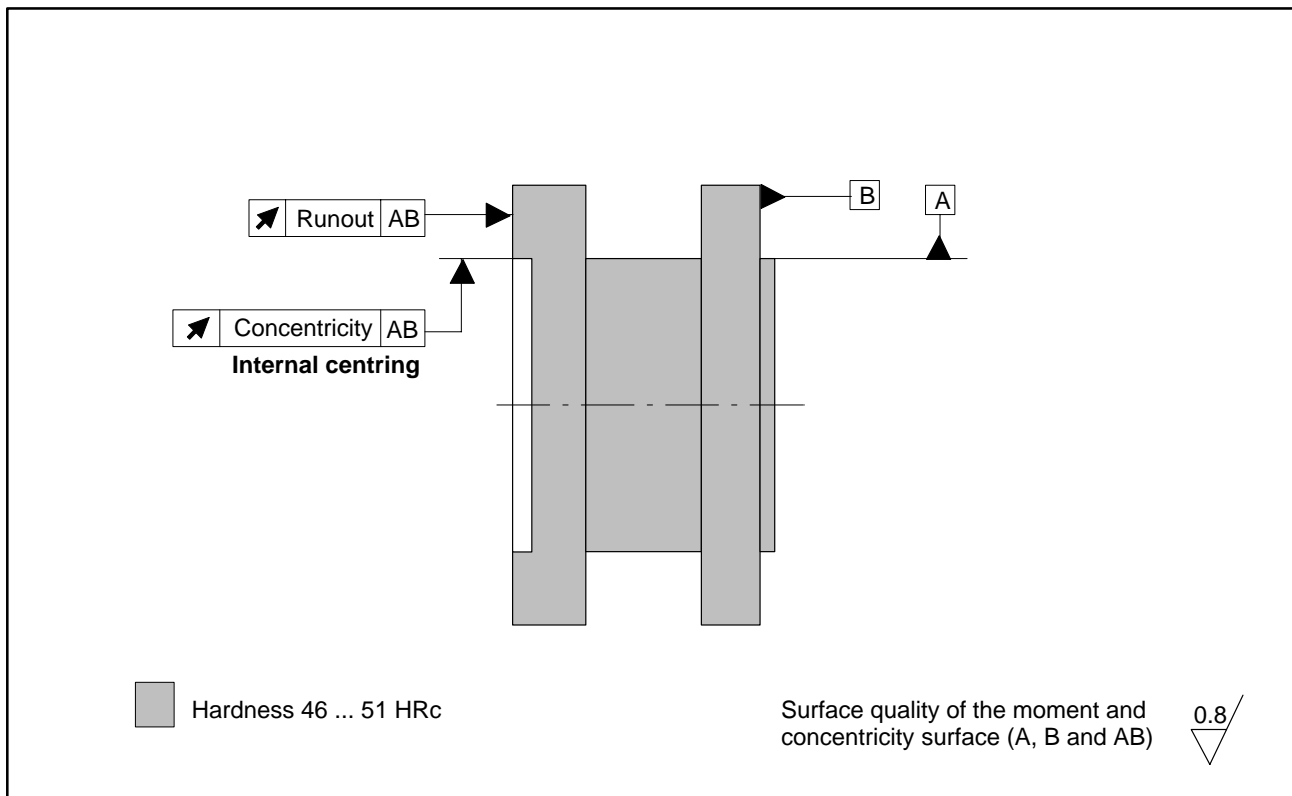

Measuring range	Runout tolerance (mm)	Concentricity tolerance (mm)
500 N·m	0.01	0.01
1 kN·m	0.01	0.01
2 kN·m	0.02	0.02
3 kN·m	0.02	0.02
5 kN·m	0.02	0.02
10 kN·m	0.02	0.02

Änderungen vorbehalten.
Alle Angaben beschreiben unsere Produkte in allgemeiner Form. Sie stellen keine Eigenschaftszusicherung im Sinne des §459, Abs. 2, BGB dar und begründen keine Haftung.

Hottinger Baldwin Messtechnik GmbH

Postfach 10 01 51, D-64201 Darmstadt
Im Tiefen See 45, D-64293 Darmstadt
Tel.: 061 51/ 8 03-0; Fax: 061 51/ 8039100
E-mail: support@hbm.com www.hbm.com



measurement with confidence